

ICP6919



ICP6919

V1.3

INDUSTRIAL OPERATION PANEL

Support Celeron™ 4205U/J1900/Core i5 7200U

Highly integrated cantilever industrial system operation panel

Specifications:



		ICP6919
Processor	CPU	Support Intel® Celeron™ 4205U/J1900/Core i5 7200U
	Main Frequency	Dual Core 1.8GHz/Quad Core 2.0GHz/Dual Core 2.5Hz
	L3 Cache	2MB/2MB/3MB
	Memory	1*DDR3L-1600, max 8GB / 1*DDR4 2400MHz, max 16G
	Storage interface	1 x 2.5" SATA HDD + 1 x mSATA
I/O	Ethernet	2 x Intel 1000Mbps RJ-45 Ethernet interface
	Audio	Optional
	USB	4 x USB3.0/2.0/1.1
	Serial port	2 x RS-232 / RS-485 with surge protection, RS485 support automatic flow control
	Expansion slot	1 x Mini-PCIe slot, extensible 3G, WIFI wireless card
Physical	Weight	11.3KG
	Pensile Direction	Optional Up or Down
	Fixed Stand of Cantilever	Suitable for full series
	Handle of Operation Panel	Standard
	Keyboard tray	optional
	Operation Button	Optional Item, Nodka Standard: USB, Rotatable switch, Push button (Green , Red), Key switch, Emergency stop switch)
	Dimension (W x H x D)	573mm x 437mm x 139.5mm
OS	OS	Windows 7, Windows8, Windows10, Linux
Power	DC input	DC 12-24V support reverse polarity protection, overvoltage protection, overcurrent protection
	Maximum Power Dissipation	Depend on the processor
LCD	LCD Type	19" SXGA TFT
	Resolution	1280*1024
	Colors	16.7MB
	Active Area (W x H)	376.32mm x 301.06mm
	Backlight	LED
	MTBF (hour)	30000hrs
	Pixel Pitch (H x V)	0.294 x 0.294
	Luminance	250cd/m2
	Contrast Ratio	1000:1
	Viewing Angle	(L) 85 / (R) 85 / (T) 80 / (B) 80
Touchscreen	Touchscreen type	Capacitive touch screen
	Transmittance	> 81%
	Response Time (touch pen)	< 5ms
	Surface Hardness	Mohs Hardness 7H
	Click Life	250g / 100,000,000 times
	Multi-touch	10 points
	Work Temperature	-10 ~ 60°C (14~140°F)
Storage Temperature	-20 ~ 80°C (-4 ~ 176°F)	
Relative Humidity	5~95% (Non-condensation)	
Environmental	Shake	SSD applied: 1.5 Grms, IEC 60068-2-64, random, 5 ~ 500 Hz, 1 hr/axis
	Shock	SSD applied: 10 G, IEC 60068-2-27, Half-sine wave, 11ms duration
	EMC	CE/FCC Class B
	Water-proof	IP65

ICP6919 Dimension:

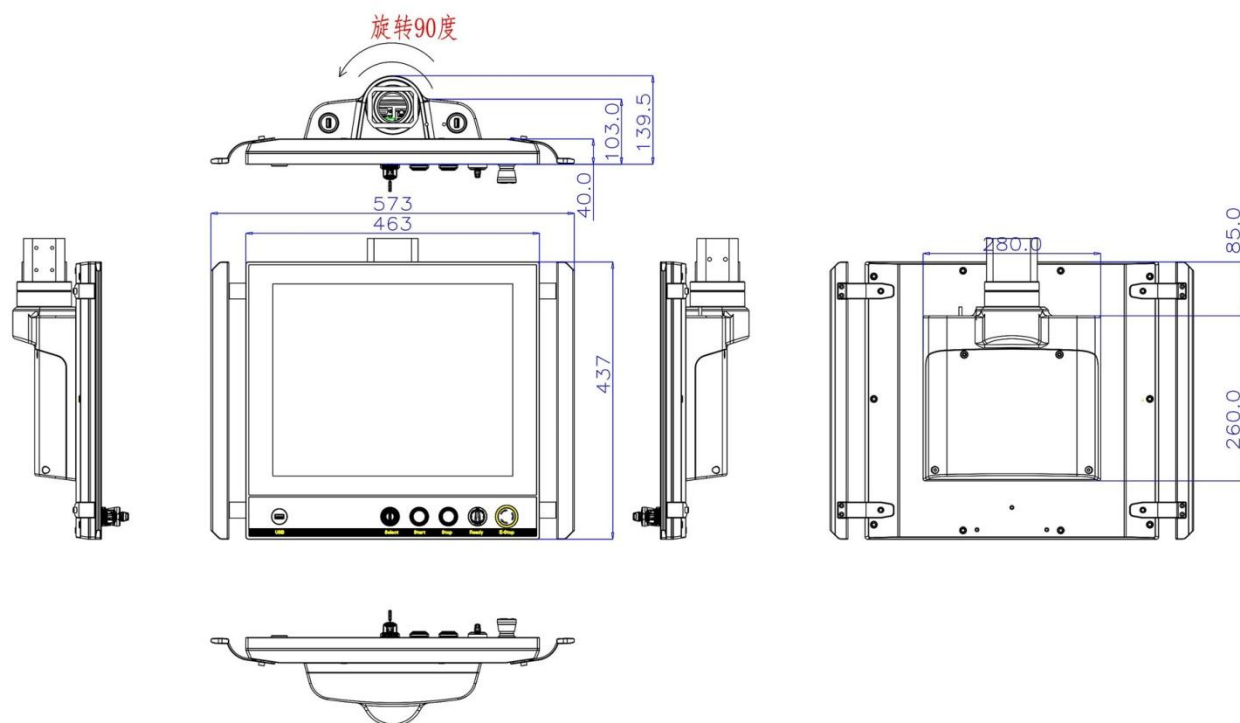

Order Price Table:

ICP6919	Specification
ICP6919-C-WL4205U-4G	19"LCD/1280*1024/capacitive touchscreen/4205U 1.8G CPU/4G memory/no hard disk /DC12V~24V input
ICP6919-C-SL7200U-4G	19"LCD/1280*1024/ capacitive touchscreen /7200U 2.5G CPU /4G memory/no hard disk /DC12V~24V input
ICP6919-C-J1900-4G	19"LCD/1280*1024/ capacitive touchscreen /J1900 2.0G CPU /4G memory/no hard disk /DC12V~24V input